

# Data Sheet

**STIEBEL ELTRON**

## WSH 20

### Infrared Sensor Tapware

Battery operated hands-free sensor tap for use with DEM 6 instantaneous water heater



WSH 20



Temperature adjustment lever

#### The advantages

- › Sold packaged with DEM 6 instantaneous water heater
- › Infrared sensor technology for hands-free operation
- › Adjustable temperature
- › Modern design
- › Removable cover for simple battery replacement

		SENSOR TAPWARE
MODEL NUMBER		WSH 20
Sealed unvented type		Pressurised
Type of installation		Monobloc mixer tap
Surface finish		Chrome plated
Connection		Connection hoses – G1/2
Max. throughput	l/min	5
Minimum supply pressure	kPa	100
Max. DHW temperature	°C	80
Power supply		Battery (DC)
Rated voltage	V	6
Battery type		1 x CR-P2 6 V
Spout height	mm	103
Reach	mm	103
Weight	kg	2.2
Approvals		WaterMark Lic No. WMKA20371

WSH 20 Dimensions

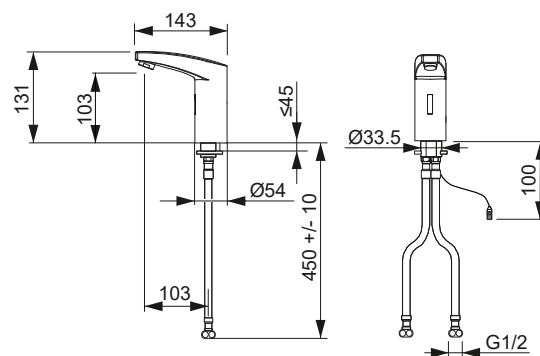

#### Warranty

For full warranty information please visit [www.stiebel.co.nz](http://www.stiebel.co.nz).

#### Technical Support

Stiebel Eltron NZ Limited  
Telephone: 09 486 2221  
Website: [stiebel.co.nz](http://stiebel.co.nz)

STIEBEL ELTRON is committed to our policy of continual improvement, some features may have subsequently been changed or even removed. Our advisors will be happy to consult with you regarding the currently applicable equipment features. The images used in this brochure are for reference only.